

OS-214 plus Desktop Barcode Printer

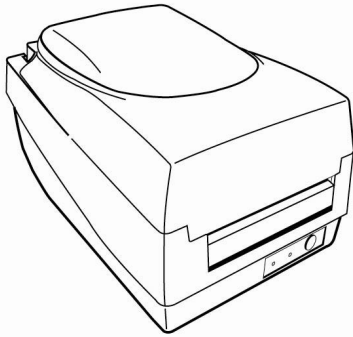

User's Manual

Proprietary Statement

This manual contains proprietary information of Argox Information Co., Ltd. It is intended solely for the information and use of parties operating and maintaining the equipment described herein. Such proprietary information may not be used, reproduced, or disclosed to any other parties for any other purpose without the expressed written permission of Argox Information Co., Ltd.

Product Improvements

Continuous improvement of products is a policy of Argox Information Co., Ltd. All specifications and signs are subject to change without notice.

FCC Compliance Statement

This equipment has been tested and found to comply with the limits for a Class A digital device, pursuant to Part 15 of the FCC Rules. These limits are designed to provide reasonable protection against harmful interference in a residential installation. This equipment generates, uses, and can radiate radio frequency energy and, if not installed and used in accordance with the instructions, may cause harmful interference to radio communications. However, there is no guarantee that the interference will not occur in a particular installation. If this equipment does cause harmful interference to radio or television reception, which can be determined by turning the equipment off and on, the user is encouraged to try to correct the interference by the following measures:

- Reorient or relocate the receiving antenna.
- Increase the separation between the equipment and the receiver.
- Connect the equipment into a different outlet on a different circuit.
- Consult the dealer or an experienced Radio/TV technician for help.

This unit was tested with shielded cables on the peripheral devices. Shielded cables must be used with the unit to insure compliance. The user is cautioned that any changes or modifications not expressly approved by Argox Information Co., Ltd. could void the user's authority to operate the equipment.

Liability Disclaimer

Argox Information Co., Ltd. takes steps to assure that the company's published engineering specifications and manuals are correct; however, errors do occur. Argox Information Co., Ltd. reserves the right to correct any such errors and disclaims any resulting liability. In no event shall Argox Information Co., Ltd. or anyone else involved in the creation, production, or delivery of the accompanying product (including hardware and software) be liable for any damages whatsoever (including, without limitation, damages for loss of business profits, business interruption, loss of business information, or other pecuniary loss) arising out of the use of or the results of use of or inability to use such product, even if Argox Information Co., Ltd. has been advised of the possibility of such damages.

A Letter to Our Customers

Dear Customers,

Congratulation on selecting an Argox OS series printer!
We believe soon you will find that you have made a
cleverest choice!

This booklet is a small gift from us. It is intended for
helping you to know your printer better, then further to
optimize it. Basically, this booklet contains two parts:
operation guidance and related valuable information.

In the part of the operation guidance, we will furnish you
with a lot of complementary illustrations, so you may pick
up those operation guides more quickly.

In the latter chapters of Trouble Shooting, Maintenance as
well as Reference Technical information, which we think,
you may need them just in case. Therefore, for your quick
reference, we try to table them as much as possible.

Enjoy your reading and have a good time with your printer!

Best wishes,
Argox Information Co., Ltd.

Table of Contents

Getting Started	1
Unpacking	1
Package Contents	2
Connecting the Power Supply	3
Getting to Know Your Printer	4
Parts and Features	4
Controls and Indicators	7
Loading Ribbon and Media	9
Loading a Ribbon	9
Loading Media	14
Standard Mode	14
Peel Off Mode	19
Cutting Mode	23
Configuration	25
Performing Calibration	25
Printing a Configuration Report	25
Resetting to Factory Default Settings	26
Computer Connections	27
USB Interface Requirements	27
Serial (RS-232) Interface Requirements	28
Parallel Interface Requirements	29
Serial and Parallel Cabling Requirements	29
Communicating with the Printer	30
Before Installation	30
Installing the Driver (auto install driver)	30
Installing the USB Driver (Plug and Play)	34
Setting Parameters	39
Parameters for Win 98	40
Parameters for Win 2000	43
For NT 4.0	47

For Win XP	49
Troubleshooting.....	53
LED Diagnosis.....	53
Miscellaneous	55
Recovery	56
Caring for Your Printer.....	57
Cleaning	57
Thermal Print Head.....	57
Paper Sensor.....	57
Technical Reference	60
General Specifications	60
Fonts, Bar Codes and Graphics Specification.....	62
Printer Programming Language A, PPLA	62
Printer Programming Language B, PPLB.....	63
Interface Specifications.....	64
Serial	64
Connection with host:	65
Parallel (Centronics)	67
Auto Polling	67
ASCII TABLE.....	68
Appendix I - Installing Dispenser Kit	69
Top Cover.....	69
Middle Cover	70
Base Housing	71
Appendix II - Installing the Cutter.....	74

Getting Started

Congratulations on choosing the Argox OS-214 plus desktop barcode printer. This manual will help you get to know your new printer. There are two parts to this manual, an operation guide and related information. The operation guide is illustrated to help you quickly become familiar with the printer. The related information includes troubleshooting, maintenance and technical information for your reference.

Unpacking

After receiving your printer, please check for possible shipping damage:

1. Inspect the outside of both the box and the printer for possible damage.
2. Open the top cover of the printer to see if the media compartments are in order.

Note: *If damage has occurred, contact your shipping company immediately to file a claim.*

3. Check whether you have received the following accessories together with the printer. If there are any items missing, please contact your local dealer.

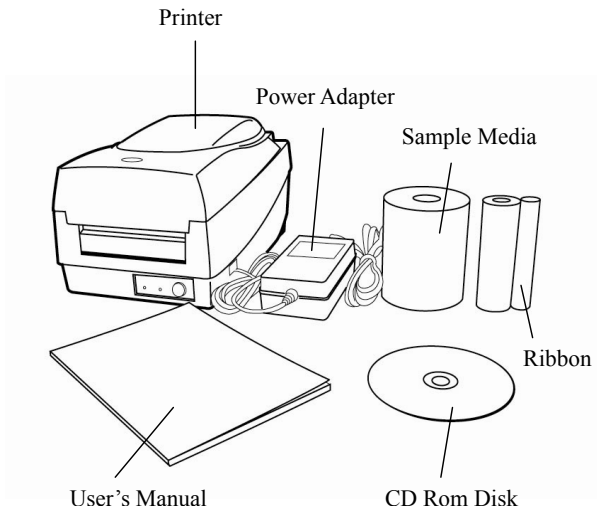

Package Contents

- Printer
- Power Adapter
- User's Manual
- CD Rom Disk
- Ribbon
- Sample Media

Connecting the Power Supply

Connect the power supply as below.

WARNING! Do not operate the printer and power supply in an area where they can get wet.

Make sure the power switch is in the "O" position, and be careful not to touch the 36-pin parallel connector.

1. Insert the barrel connector of the Power Adapter into the power jack on the back of the printer. Note the location of the power jack for different models in the diagrams below.
2. Plug the other end of the cord into an AC electrical outlet.

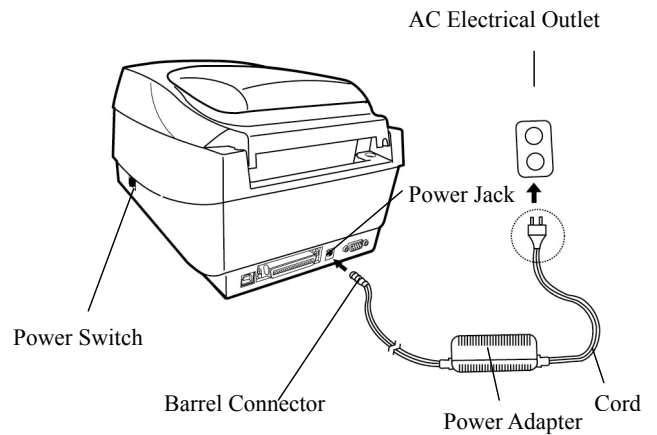

OS-214 plus

Getting to Know Your Printer

Parts and features of the OS-214 plus are illustrated below.

Parts and Features

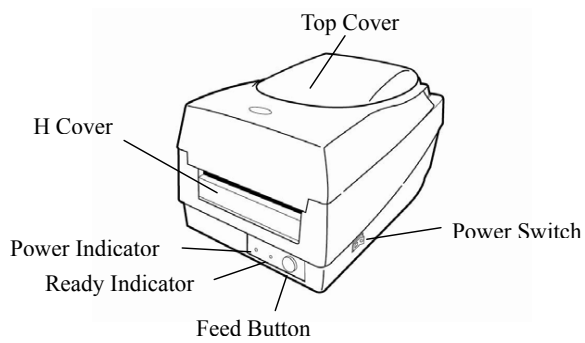

OS-214 plus

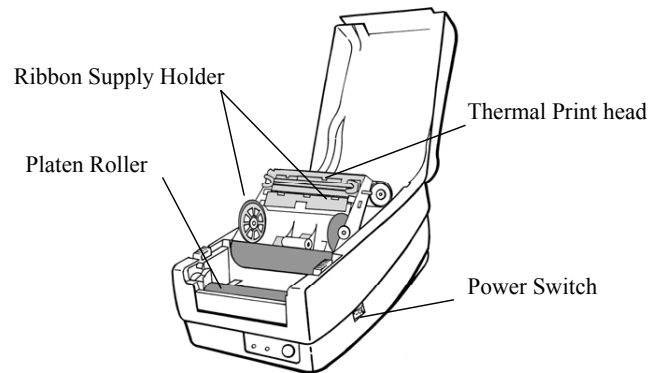
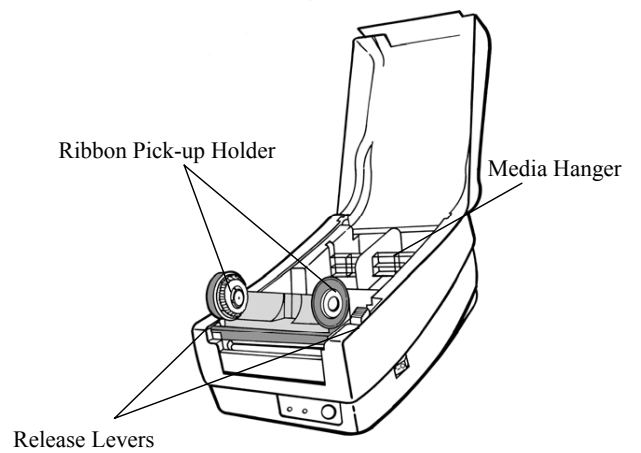

Peel-Off Option

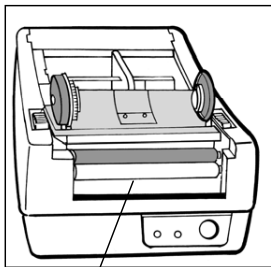

White Plastic Roller

Cutter Option

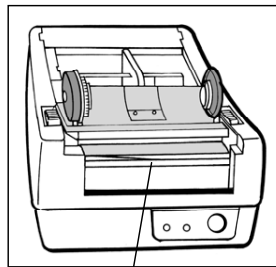

Cutter

Controls and Indicators

The printer's controls and indicators are shown in the diagram below. The following table explains control and indicator functions.

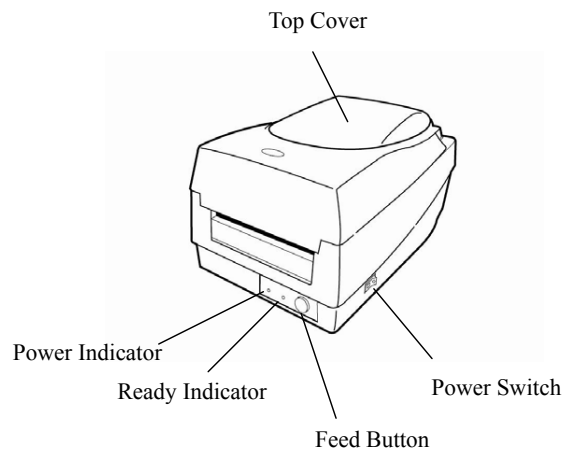

Control / Indicator	Function
Power Switch	<ul style="list-style-type: none"> On: power on Off: shut down <p>Note: Turn power off before connecting or disconnecting cables</p>
Power Indicator	<ul style="list-style-type: none"> Green light shows the power-on status Light off shows the power-off status Blinking light indicates error has occurred
Ready Indicator	<ul style="list-style-type: none"> Green shows printer is ready to operate Blinking light indicates printer is paused or data transferring Light off indicates pack flash is under processing
Feed Button	<ul style="list-style-type: none"> Press to advance labels to the first printing position Press to leave "pause" status Press to back feed if a label is not properly aligned Press and hold while turning on the power to print out a configuration profile

Loading Ribbon and Media

This section describes how to load ribbon and media into the OS-214 plus printer.

Loading a Ribbon

Note: This section does not apply to direct thermal printing.

1. Lift the top cover to expose the media compartment.
2. Unlatch the print head module by pushing the two white release levers on the sides toward the rear.
3. Turn over the print head module to expose the ribbon supply holder.

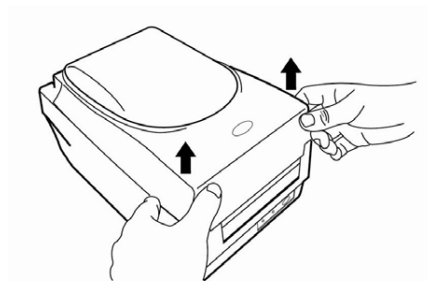

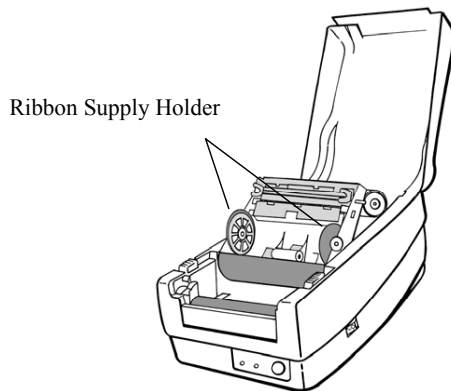
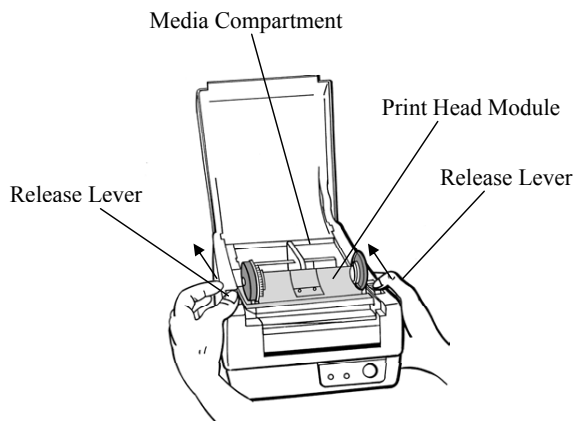

10

4. Unwrap the ribbon roll pack and separate the ribbon roll and the bare core.
5. Attach the edge of the ribbon on the bare core and wind it a little bit onto the core.
6. Insert the ribbon roll into the supply holder. (First snap in the left side and then the right side.)

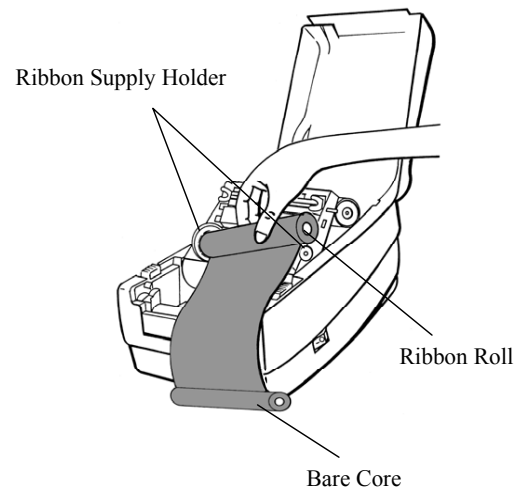

11

- Put the print head module down and insert the bare core into the pick-up holder. (First snap in the left side, and then the right side.)

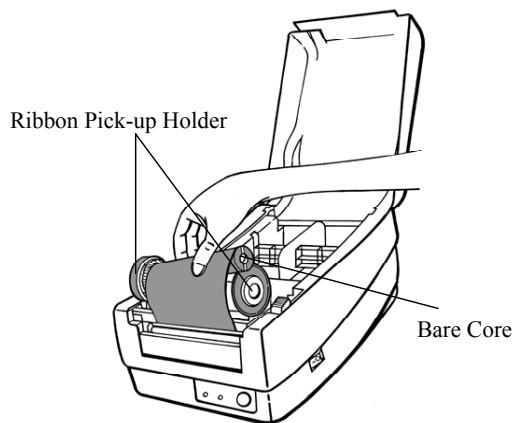

12

- Turn the wheel of the print head module to ensure the ribbon is tightly wound.
- Press down the print head module firmly until you hear a snap.

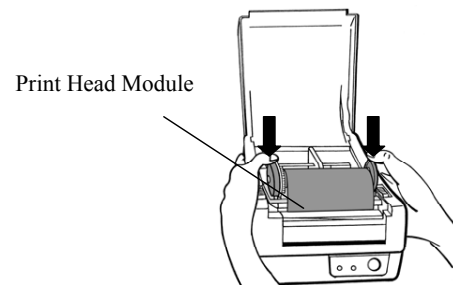
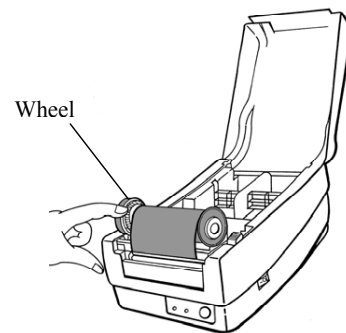

13

Loading Media

The OS-214 plus offers three different loading modes: standard, peel-off, or cutting.

- **Standard mode** allows you to collect each label freely.
- **Peel-off mode** peels backing material away from the label as it prints. After a label is removed, the next label prints.
- **Cutting mode** automatically cuts the label after it prints.

Standard Mode

1. Lift the top cover to expose the media compartment.

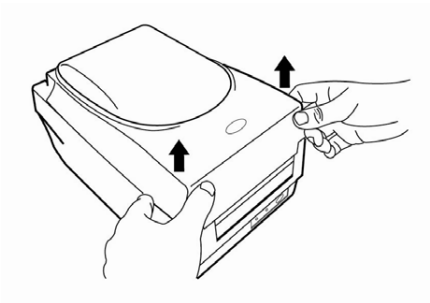

14

2. Remove the media hanger.

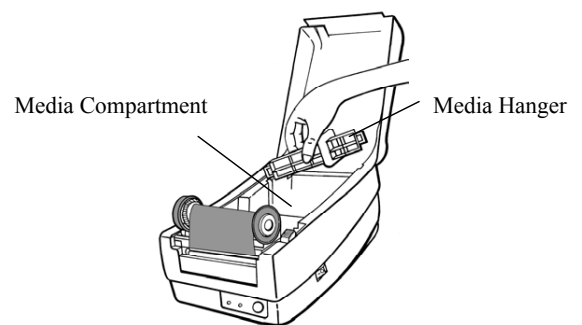

3. Load the media roll onto the hanger from left to right.

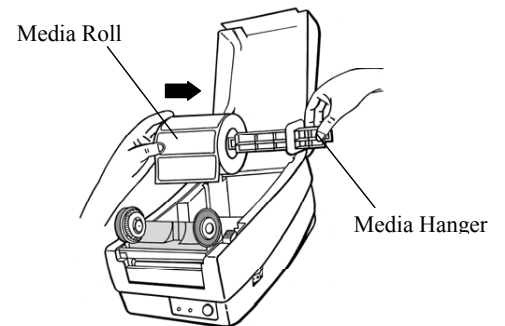

15

4. Click the media hanger back into the media compartment.
5. Align the media roll to the left end.
6. Move the shield from right to left until it leans against the media.

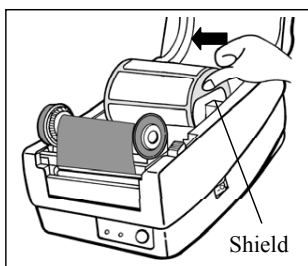
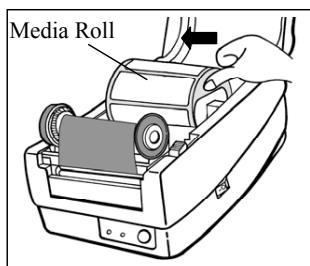
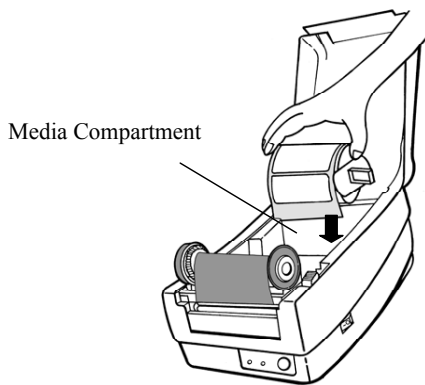

16

7. Unlatch the print head module.
8. Hold the print head module upright with one hand to allow the media to pass under it. Lead the media through the media guides with the other hand.
9. Lead the media over the platen roller.

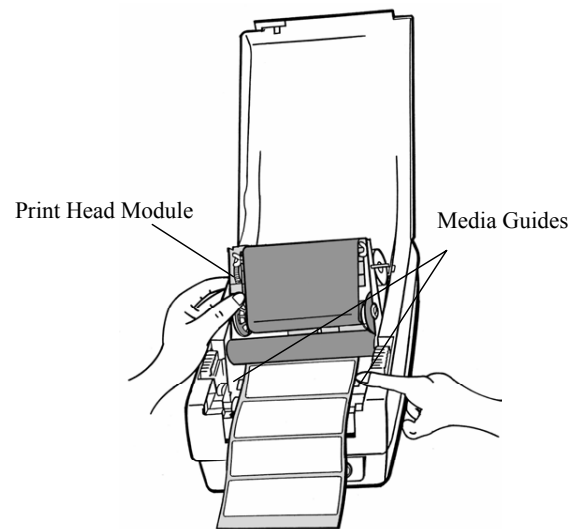

17

10. Put the print head module down and press down firmly until you hear a snap.
11. Close the top cover and turn on the printer or press the "FEED" button if the printer is already on.

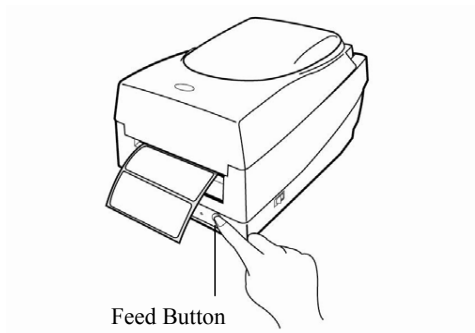
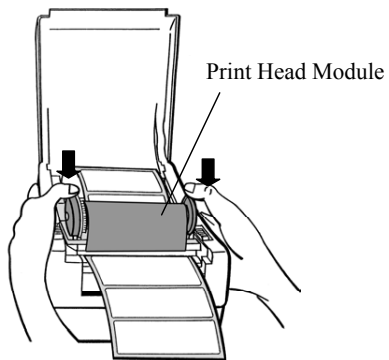

18

Peel Off Mode

Note: For Peel-off mode you must first install the dispenser kit. Please refer to Appendix I.

Follow Steps 1 to 8 listed in Standard Mode above.

9. Remove enough labels to expose approximately a 6" length of backing paper.

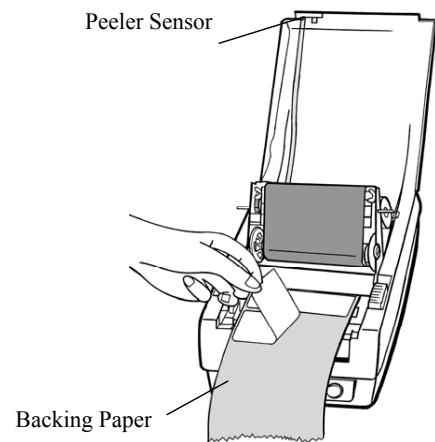

19

10. Trim the front edge of the label backing paper with scissors or a knife.
11. Lead the backing paper over the dispenser bar, then thread it back into the slot between the dispenser bar and H cover, ensuring that it is inserted between the white plastic roller and platen roller.

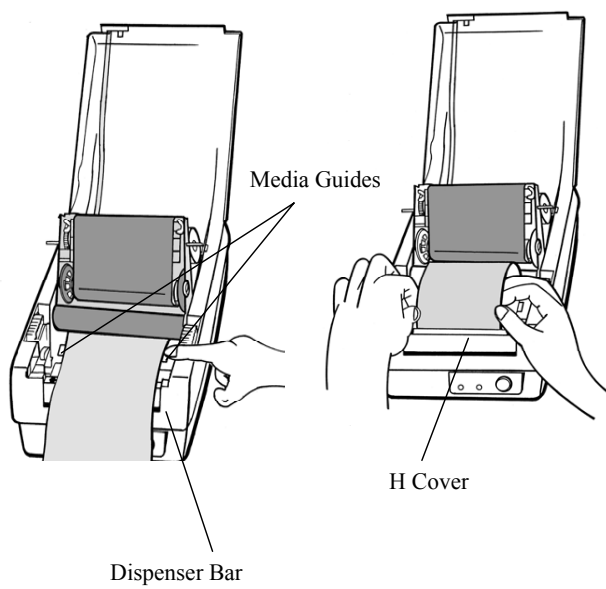

12. Press the "FEED" button for the label backing paper to come out from the slot under the H cover.
13. To remove any slack, rewind the media onto the roll. Press down the print head module firmly.

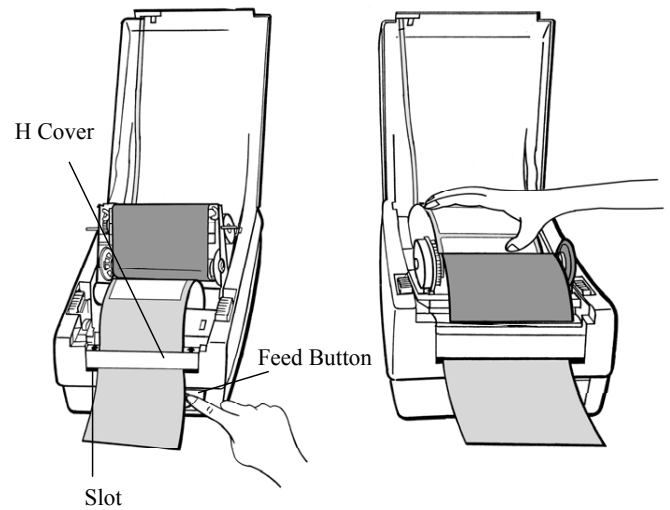

14. Close the top cover and turn on the printer or press the "FEED" button if the printer is already on.

Note: The "FEED" button does not make the printer peel.
Peeling occurs only when the software is properly set.



Cutting Mode

Note: For Cutting mode you must first install the cutter. Please refer to Appendix I.

Follow Steps 1 to 8 listed in Standard Mode above.

9. Thread the media over the platen roller, then route the media through the slot of the cutter module.
10. Press down the print head module firmly.

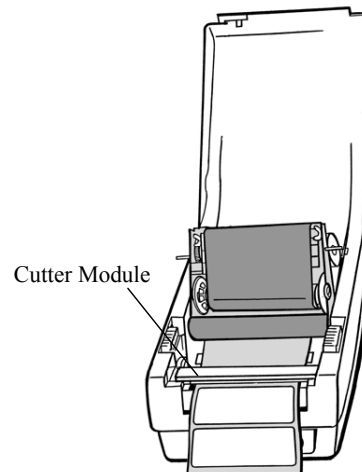

11. Close the top cover and turn on the printer or press the "FEED" button if the printer is already on.

Note: The "FEED" button does not make the printer cut. Cutting occurs only when the software is properly set.

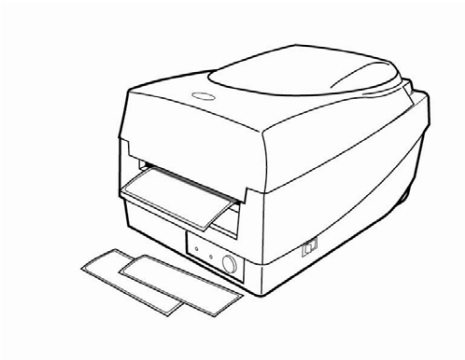

Configuration

This section discusses calibration, printing configuration and resetting the printer to factory defaults.

Performing Calibration

1. Press and hold the feed button while turning on the power, until the printing motor is activated.
2. Calibration is performed while the printer automatically feeds the label stock for a certain length.

Important! You must always carry out calibration when changing media. Failure to do so will result in improper detection by the label sensor.

Printing a Configuration Report

1. Press and hold the "Feed" button while turning on the power, until the printing motor is activated.
2. After feeding 12-inches of blank media, the printing motor suspends for one second and then prints out a configuration profile. The profile includes firmware version, ROM checksum, RS232, thermal transfer/direct thermal settings, hardware configuration, and font types.
3. At PPLB emulation, the printer enters character dump mode. To exit from dump mode, press the feed button again.

Resetting to Factory Default Settings

1. Turn on the printer and wait for 5 or more seconds.
2. Press the "Feed" button for 10 seconds, and the "Ready" indicator and "Power" indicator will go off in order.
3. When the two indicators relight, release the feed button.
4. The printer feeds approximately 3 ~5 blank labels, and then resets to the factory defaults.

Note: *All settings are stored in flash and are retained even after the printer is turned off.*

Computer Connections

Note: *You must insert the power supply's barrel connector into the power jack on the back of the printer before connecting communication cables.*

This printer comes with a USB interface, a nine-pin Electronics Industries Association (EIA) RS-232 serial data interface and a standard Centronics parallel interface. You must supply the required interface cable for your application.

Note: *This printer complies with FCC Rules and Regulations, Part 15, for Class B Equipment, for use with fully shielded six-foot data cables. Use of longer cables or unshielded cables may increase radiated emissions above Class B limits.*

USB Interface Requirements

The Universal Serial Bus (USB) interface is version 2.0 and 1.1 compliant and provides a full-speed (12Mb/s) interface that is compatible with your existing PC hardware. The USB's "plug and play" design makes installation easy. Multiple printers can share a single USB port/hub.

Serial (RS-232) Interface Requirements

The required cable must have a nine-pin "D" type male connector on one end, which is plugged into the mating serial port located on the back of the printer. The other end of the signal interface cable connects to a serial port on the host computer.

For technical and pin-out information, please refer to the Reference Technical Information, Interface Specification.

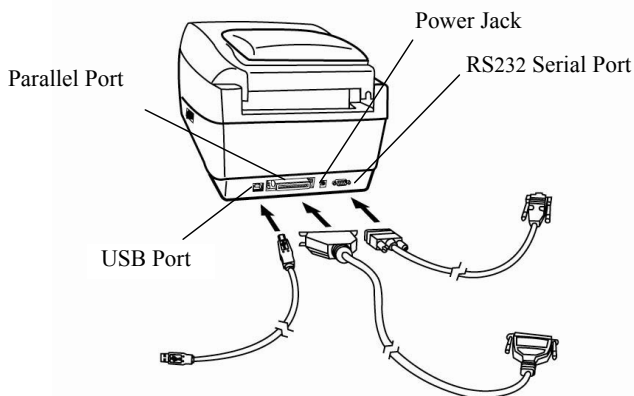

Parallel Interface Requirements

The required cable (IEEE 1284-compliant is recommended) must have a standard 36-pin parallel connector on one end, which is plugged into the parallel port located on the back of the printer. The other end of the parallel interface cable connects to the printer connector at the host computer. For pin-out information, refer to the Reference Technical Information, Interface Specification.

Serial and Parallel Cabling Requirements.

Data cables must be of fully shielded construction and fitted with metal or metalized connector shells. Shielded cables and connectors are required to prevent radiation and reception of electrical noise.

To minimize electrical noise pickup in the cable:

- Keep data cables short (6 ft or 1.83m recommended).
- Do not tightly bundle the data cables with power cords.
- Do not tie the data cables to power wire conduits.

Notes:

1. Centronics allows a much higher communication speed than serial.
2. The printer automatically detects parallel or serial port. No need to set a switch or send a command.
3. Default settings are included in the configuration report.

Communicating with the Printer

The bundled printer driver can be applied to all applications under Windows 98/2000/NT, and Windows XP. With this driver you can run any popular Windows software applications such as MS-Word and print to this printer.

Before Installation

1. Check the contents of the driver to ensure it is complete.
2. Make a backup copy of the driver.

Installing the Driver (auto install driver)

1. Double click the driver file (Label Dr. 200 or Label Dr. 300) to execute in Windows.
2. Click "Next".

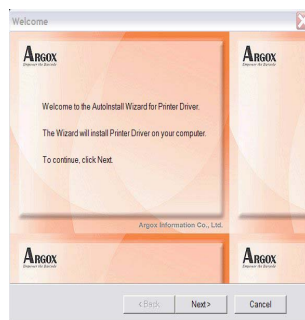

30

Select a driver for your printer and click "Next". For 203 dpi modes with 4 inches print width, you should select Label Dr.200 (4 inch model).

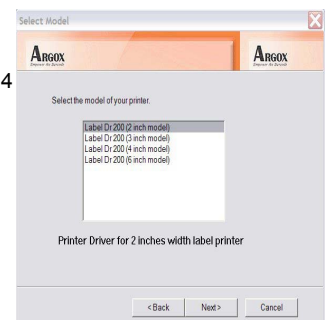

3. Select the port of the printer and click "Next".

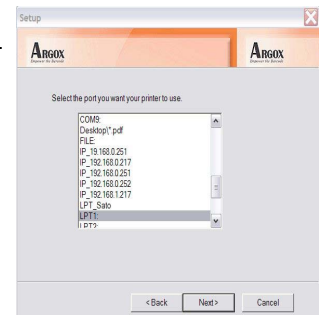

31

4. After the related files are copied to your system, click "Next".

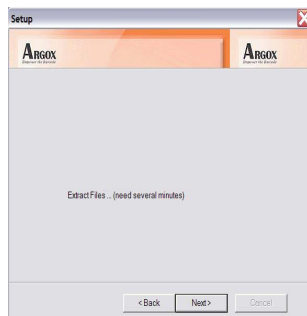

5. After the installation is complete, click "Finish".



Note:

1. If you are updating the driver, previous driver files are overwritten automatically.
2. If you install new bar code application software such as ArgoBar, LabelView or CodeSoft, you may activate the Label Dr. 200 (or Label Dr. 300) driver and set it as the current printer driver:

3. If you install new bar code application software such as Bartender Ultra Lite, you should activate the seagull driver for Argox printer.

ArgoBar

File → New → Select Printer → Label Dr. on LPT1: → OK

LabelView

File → Select Printer → Label Dr. on LPT1: → OK

CodeSoft

File → Printer → Windows → Label Dr. on LPT1: → OK

LabelMatrix

File → Printer Setup → Label Dr. on LPT1: → OK

Nicelabel

File → Printer Setup → Label Dr. on LPT1: → OK

Bartender

File → Printer Setup → Label Dr. on LPT1: → OK

Installing the USB Driver (Plug and Play)

Note:

The printer driver needs to install version 1.4.00 or later and support "USB Plug and Play" for Windows XP, Windows 2003 and Windows 2000.

1. Extract the PrinterDriver.exe to the fixed route. ("C:\Label Dr. 200", for example)
2. Connect the label printer to a computer with a USB cable.
3. Turn on the printer's power and the system detects the device automatically.
4. Select "Install from a list or specific location (Advanced)", click "Next".



34

5. Select "Search for the best driver in these locations" and choose "Include this location in the search". Input the location of printer driver, click "Next".

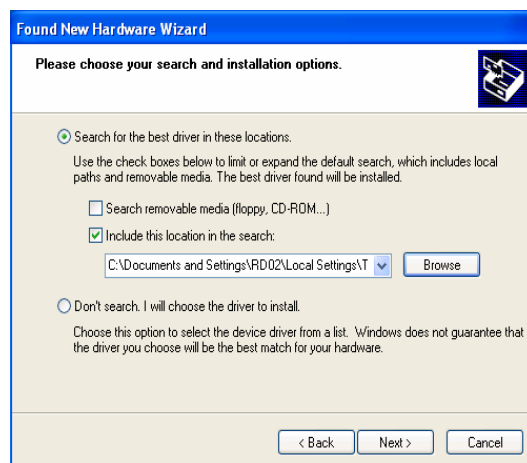

35

6. Select "Continue Anyway".

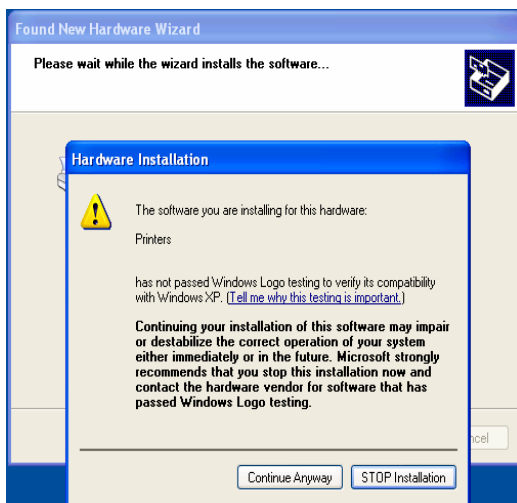

36

7. Click "Finish".

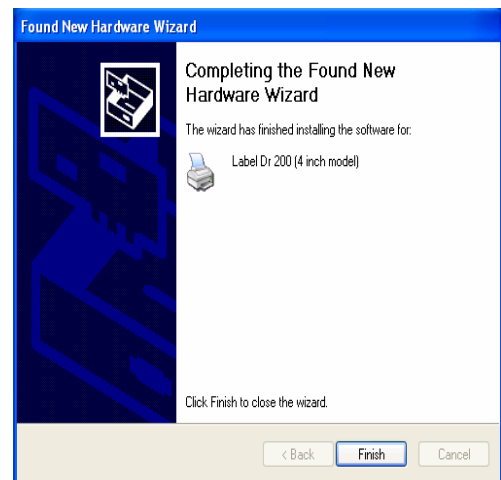

8. The Label Dr200 (4 inch model) printer is added in "Printers and Faxes".

9. Reboot the system.

37

10. The system assigns the USB port for Label Dr200 (4 inch model) printer

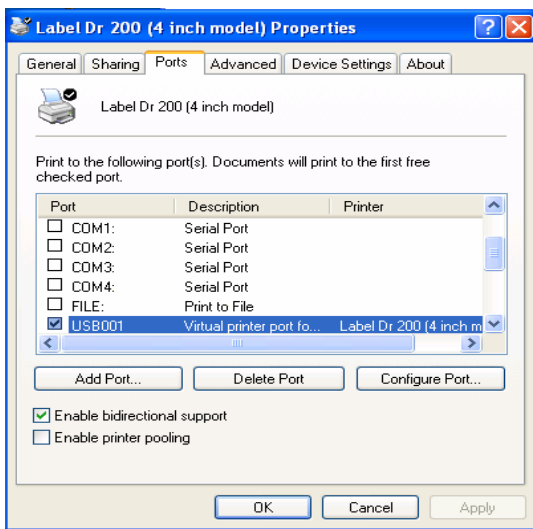

Setting Parameters

After installing the driver, follow the path below to set parameters:

Start → Settings → Printers → Label Dr. → Properties

Parameters include:

Ports	Select the IO port to link with the printer. The port may be USB, parallel (LPT), serial (COM), network port, or file.
Paper size	Select the proper size. If there is no desired size, select "Custom" to define paper size.
Orientation	Set portrait or landscape.
Paper source (Media type)	T/T stands for thermal transfer (ribbon) mode and D/T for direct thermal mode (without ribbon).
Media choice (Darkness)	Set the heat value or darkness from this field. Darkness values range from 0 to 15.
Copies	This function designates the number of printed copies of each page.
More options (Accessories)	To use the cutter or peeler function, enter More Options and select one of the items.
Device options (Speed)	Set print speed. For the OS-214 plus, the speed ranges from 1~ 3 ips.

Parameters for Win 98

Ports

In the Properties menu:

- Click "Details"
- Select the IO port.
- Click "OK"

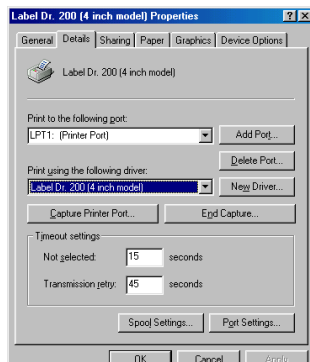

Output bin

(Accessory setting)

In the Properties menu:

- Click "Paper"
- Click "More Options"
- Select Enable w/o cutter, peeler
- Click "OK"

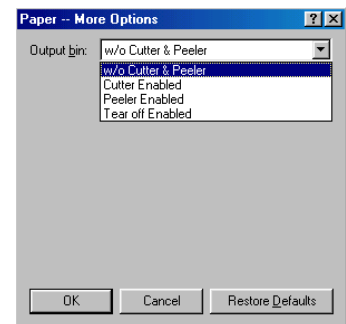

Paper size

Orientation

Paper source

(Media type)

Media choice

(Darkness)

Copies

In the Properties menu:

- Click "Paper"
- Click items to select the desired parameters
- Click "OK"

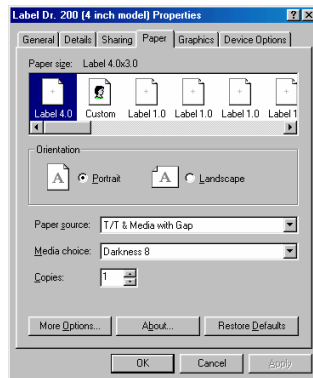

Print quality

(Speed)

In the Properties menu:

- Click "Device Options"
- Select parameters
- Click "OK"

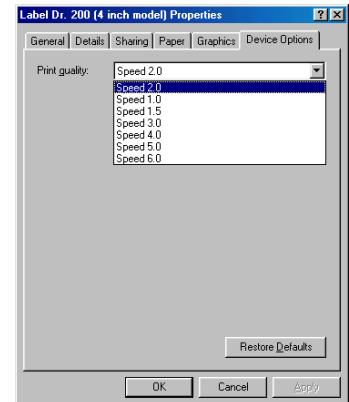

Create a custom size

In the Properties menu:

- Click "Paper"
- Select "Custom"
- User-Defined Size
- Set a custom size
- Click "OK"

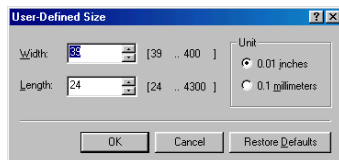
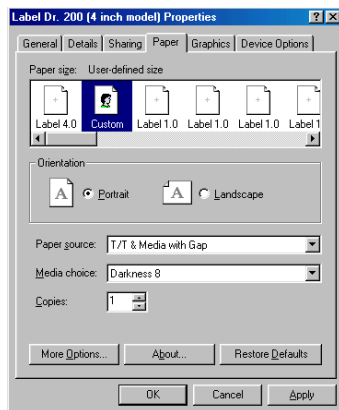

42

Parameters for Win 2000

Ports

In the Properties menu:

- Click "Ports"
- Select the IO port
- Click "OK"

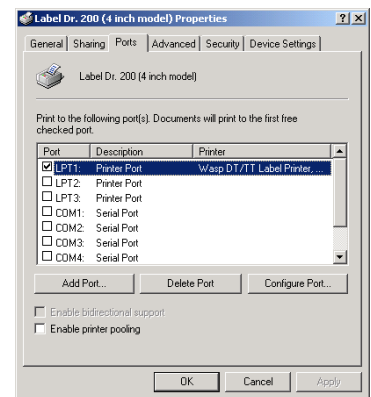

Paper source (Media type)

In the Printers menu:

- Right click
- Select "Printing Preferences"
- Click "Paper/Quality"
- and select media type
- Click "OK"

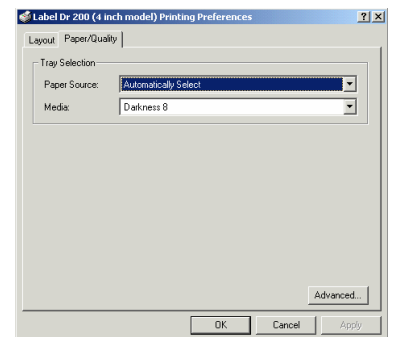

43

Orientation Page order

In Printing Preferences:

- Click "Layout"
- Select "Portrait" or "Landscape"
- Click "Page order"
- Select "Front to Back" or "Back to Front"
- Click "OK"

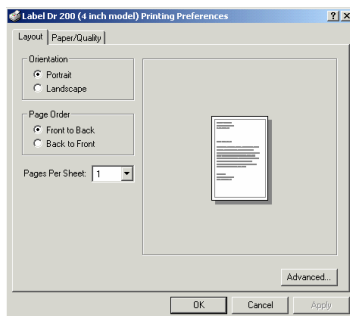

Paper size setup

In Printing Preferences:

- Click tag "Layout"
- Click button "Advanced"
- Click "button Customize"
- Select "paper size" or add new paper size.
- Click "OK"

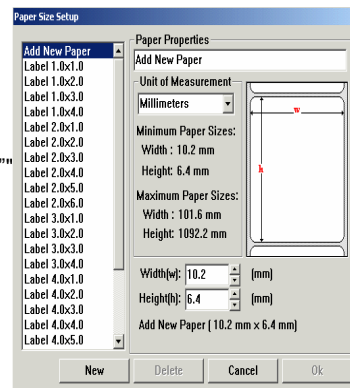

Paper size

Copies

Print quality (Speed)

Output bin (Accessory setting)

In Printing Preferences:

- Click "Layout"
- Click "Advanced"
- Click each item to select parameters
- Click "OK"

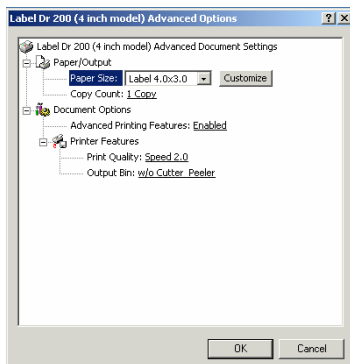

Create a custom size

In the Printers menu:

- Right click
- Select "Server Properties"
- Enter a form name for in "Form Description for"
- Reset paper size in "Measurements"
- Click "OK"

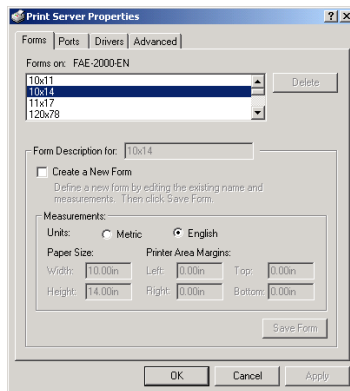
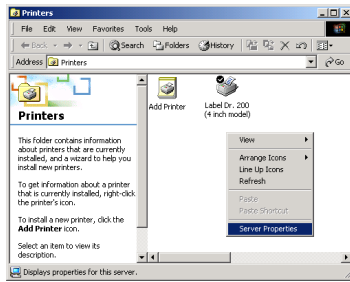

46

For NT 4.0

Ports

In the Properties menu:

- Click "Ports"
- Select IO port
- Click "OK"

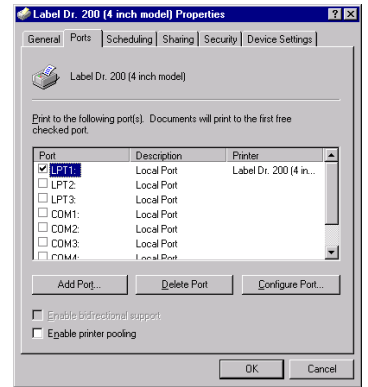

Paper size Orientation

Paper source

(Media type)

Copies

Media choice

(Accessory setting)

In the Printer's menu:

- Right click
- Select "Document Defaults"
- Click "Advanced"
- Click items to select desired parameters

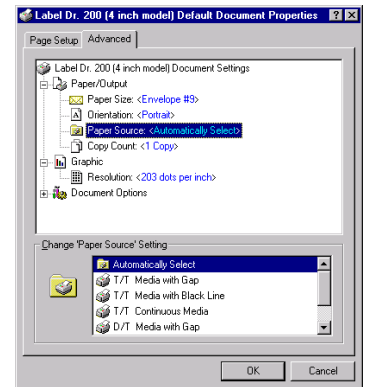

47

Paper/Output
(Speed)
Print quality
(Darkness)

In Default Document:
→ Click "Advanced"
→ Click item to select
desired parameters
→ Click "OK"

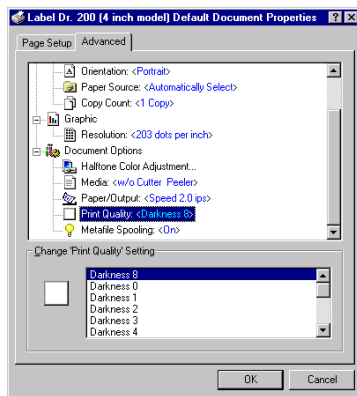

Create a custom size

Please refer to **Create a custom size** in Win 2000 above.

48

For Win XP

Ports

In the Properties menu:
→ Click "Ports"
→ Select the IO port
→ Click "OK"

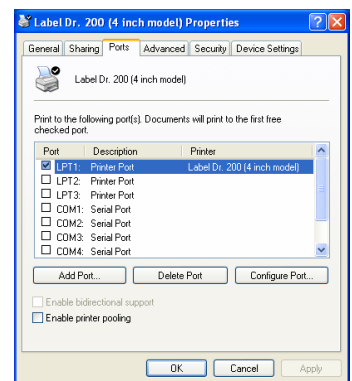

Paper source
(Media type)

In the Printers menu:
→ Label Dr
→ Right click
→ Select "Printing
Preferences"
→ Click "Paper Quality"
→ Select media type
→ Click "OK"

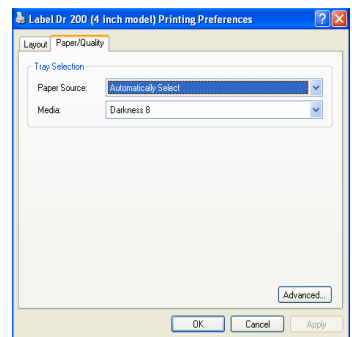

49

Orientation Page order

In Printing Preferences:
→ Click "Layout"
→ Select "Portrait" or
"Landscape"
→ Click "Page order"
→ Select "Front to Back"
or "Back to Front"
→ Click "OK"

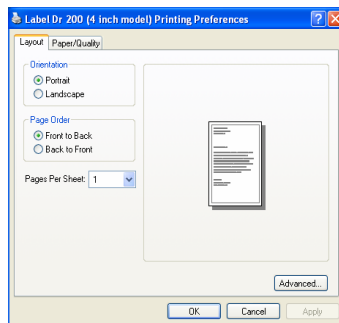

Paper size setup

In Printing Preferences:
→ Click tag "Layout"
→ Click button "Advanced"
→ Click button "Customize"
→ Select "paper size" or
Add new paper size.
→ Click "OK"

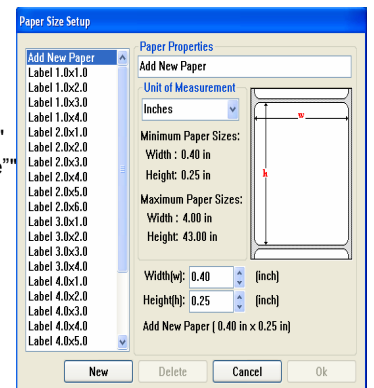

Paper size Copies

Print quality
(Speed)

Output bin
(Accessory setting)

In Printing Preferences:
→ Click "Layout"
→ Click "Advanced"
→ Click items to select
parameters
→ Click "OK"

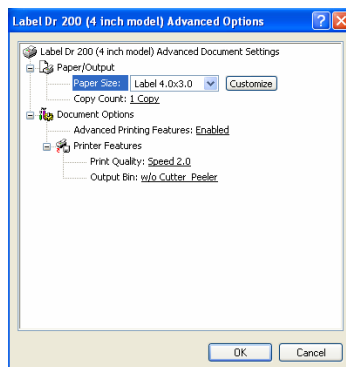

Create a custom size

In the Printers menu:

- Right click
- Select "Server Properties"
- Enter a "Form name"
- Reset paper size in the "Form description"
- Click "OK"

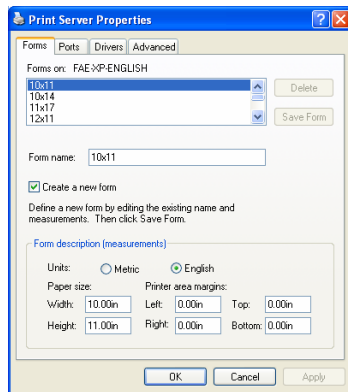
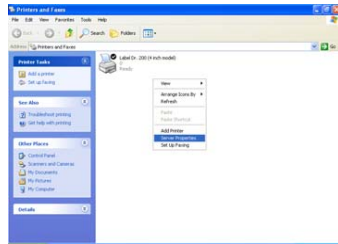

Troubleshooting

Normally, when the printer is not working properly, the "Power" LED blinks continuously; while printing and communication between the host and printer stops.

LED Diagnosis

Power and Ready LEDs blinking continuously indicates printer errors. To understand the problem, please observe the Power and Ready LEDs and refer to the following solutions:

LED Indicators: Power and Ready LEDs blink at the same tempo

Power LED	Ready LED
ON	ON
OFF	OFF

Possible Problems	Solutions	Remarks
Miss-detect gap	Check the label path Check the label sensor	If you use a continuous label roll and run under Windows, select continuous media.
Label stock out	Supply the label roll	
Label stock not installed	Install the label roll	
Label jam	Recover the jam	

LED Indicators: Power and Ready LEDs blink alternately

Power LED	Ready LED
ON	OFF
OFF	ON

Possible Problems	Solutions	Remarks
Ribbon out	Supply the ribbon roll	Not applicable to direct thermal type.
Ribbon jam	Recover the jam	
Ribbon sensor error	Replace ribbon sensor	

LED Indicators: Only the Power LED blinks

Power LED	Ready LED
ON	ON
OFF	ON

Possible Problems	Solutions	Remarks
Serial IO error	Check the baud rate	Not for Centronics
Memory full	Add the extension RAM	
Cutter failed, or jam at cutter	Check the cutter Recover the jam	Occurs only when installing or setting the cutter
Hardware error	Call for service	

Miscellaneous

If the host shows "Printer Time out"

1. Check if the communication cable (parallel or serial) is connected securely to your parallel or serial port on the PC and to the connector on the printer at the other end.
2. Check if the printer power is turned on.

If the power cord is connected, the power switch is at position "I" and the power LED is still not illuminated, check the fuse inside the power adapter case.

If the data has been sent, but there is no output from the printer. Check the active printer driver, and see if Label Dr. for your Windows system and the label printer has been selected.

Vertical streaks in the printout usually indicate a dirty or faulty print head. (Refer to the following examples.)

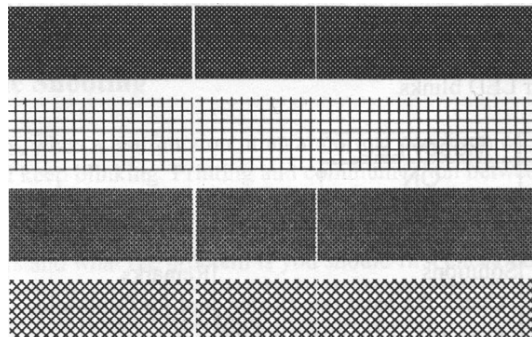

Clean the print head. If the problem persists, replace the print head.

Poor printout quality:

- The ribbon may not be qualified.
- The media may not be qualified.
- Adjust the Darkness (heat temperature).
- Slow down the print speed.
- Refer to the next chapter and clean the related spare parts.

Recovery

After correcting problems, simply press the panel button or restart the printer to continue your print jobs. Make sure the LEDs are not blinking and remember to resend your files.

Caring for Your Printer

After using eight rolls of label stock, clean the following areas of the printer.

Note: Always switch off the power before cleaning.

Cleaning

Clean the following components of the printer using a cotton bud dampened with alcohol. Do not soak the cotton bud excessively.

Thermal Print Head

Thermal paper stock and the ribbon release debris on the print head, which degrades printing quality. Clean the print head with methanol or isopropyl alcohol and a cotton bud. Do not touch the heater element with your fingers. Debris or dirt on the roller should be cleaned with alcohol.

Paper Sensor

Debris or dirt on the paper sensor can cause a miss-read or unstable detection of the label gap. Clean with a cotton bud dampened with alcohol.

Replacing the Thermal Print Head

1. Switch off the power and wait for both LEDs to go off.
2. Unlatch the print head module.
3. Remove the ribbon.
4. Push the print head firmly into the casing and shift it to the left. It will release from the module.
5. Disconnect the print head cable.
6. Disassemble the print head and the mounting bracket by releasing screws.
7. Replace with a new print head. Reassemble the print head module in reverse order. Be careful not to touch the print head elements.

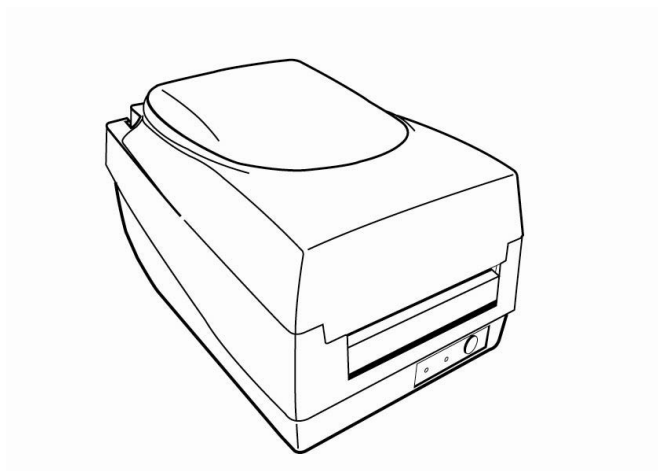

Technical Reference

General Specifications

Specification	Model OS-214 plus
Print method	Direct thermal and thermal transfer
Resolution	203 DPI (8 dots/mm)
Max. print width	4.1 in. (104 mm)
Max. print length	43 in (1092mm)
Max. print speed	3 inches (76 mm) per second
Memory	8MB SDRAM / 4MB Flash ROM
CPU Type	32 bit RISC microprocessor
Media Sensor	Reflective
Display	LED indicator x 2
Operation Interface	Button x 1
Communication Interface	Centronics parallel, RS-232 serial, USB 2.0 (full-speed)
Fonts	Int'l character sets standard 5 alpha-numeric fonts from 0.049" ~0.23" H (1.25mm ~6.0mm) All fonts expandable up to 24 x 24 4 direction 0°~270° rotation Soft fonts are downloadable
Ribbon types & Ribbon size	Wax, Wax/Resin, Resin (Outside coated ribbon) Ribbon roll-OD 1.45" (37mm) Ribbon length-max 3600" (91m)

Media Type & Media Size	Roll-feed, die-cut, continuous, fan-fold, tags, ticket in Thermal paper or plain paper Max width 4.25" (108mm) Min width 1.0" (25.4mm) Max length 43" (1092mm) Min length 0.4" (10mm) Thickness 0.0025"~0.01" (0.0635mm~0.254mm) Max roll capacity 4.3" (109mm) OD Core size 1" (25mm) ID
Label indexing	Black stripe and gap
Dimensions	L 278 x W 186 x H 153 mm, 4.4 lbs(2kgs)
Power Source	Universal switching power supply Input: 100V ~ 240 V, 1.8A, 50~60 Hz Output: 24VDC, 2.1A, 50W Max
Agency Listing	CE, FCC class A, UL / CUL, CCC, BSMI
Operation Environment	32°F ~ 104°F (0°C ~40°C) ; 10~90% non-condensing
Storage Environment	-4°F ~122°F (-20°C~50°C)
Optional Accessories	Cutter, Dispenser kit, 4MB Flash card, 4MB Super card (Combined card consists of RTC and font, or RTC and 4MB flash), ArgoKee, RTC board, External media stacker (for media roll with Max 8" OD)

Fonts, Bar Codes and Graphics Specification

The specifications of fonts, bar codes and graphics depends on printer emulation, which is a printer programming language (PPL) through which the host communicates with your printer. There are two PPLs for models OS-214 plus. They are PPLA and PPLB.

Note: *Improper firmware updating may crash printer firmware. Please contact your supplier for assistance.*

Printer Programming Language A, PPLA

Specification	Model OS-214 plus
General fonts	7 alpha-numeric fonts, OCR A and OCR B ASD
Smooth fonts	4, 6, 8, 10, 12, 14 and 18 points
Symbol sets for fonts smooth	USASCII, UK, German, French, Italian, Spanish, Swedish, and Danish/Norwegian
Courier fonts	8 symbol set (PC, PC-A, PC-B EAMA-94, Roman8, Legal, Greek and Russian)
Soft fonts	Downloadable PCL fonts
Font expandability	1x1 to 24x24
Bar code types	Code 39, Code 93, Code 128/subset A/B/C, Codabar, Interleave 2 of 5, UPC A/E/2/5 add-on, EAN-8/13, UCC/EAN Code128, Postnet, Plessey, I25 (standard/modulo 10 checksum/modulo 10 checksum and shipping bearer bar), UCC/EAN Code 128 K-MART, UCC/EAN Code 128 Random Weight, HBIC, Telepen, FIM, MaxiCode, PDF417, Datamatrix (2D symbologies).
Graphics	PCX, BMP, IMG and HEX format files

Printer Programming Language B, PPLB

Specification	Model OS-214 plus
General fonts	5 fonts with different point sizes
Symbol sets (Code pages)	8 bits: code page 437, 850, 852, 860, 863, 865, 857, 861, 862, 855, 866, 737, 851, 869, 1252, 1250, 1251, 1253, 1254, 1255. 7 bits: USA, British, German, French, Danish, Italian, Spanish, Swedish and Swiss.
Soft fonts	Downloadable soft fonts
Font expandability	1x1 to 24x24
Bar code types	Code 39(checksum), Code 93, Code 128/ subset A,B,C, Codabar, Interleave 2 of 5(checksum), Matrix 2 of 5, UPC A/E 2 and 5 add-on, EAN-8/13, Code 128UCC, UCC/EAN, Postnet, German Postcode. MaxiCode and PDF417 (2D symbologies)
Graphics	PCX and binary raster

Notes:

1. *The bare core for the ribbon must be 11 cm in length. It should have two opposite slits at two ends. If the ribbon itself is less than 11 cm, it must be aligned with the bare core at the left end when you install it.*
2. *Since this printer uses band buffer technology. If you just print texts or barcodes the maximum length is more than 30 inches. If you print many graphics the maximum length can only be a few inches with standard onboard RAM. (Extension RAM, font board and flash modules use the same connector and cannot function at the same time.)*

Interface Specifications

USB

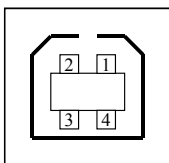

USB series "B" Receptacle Interface

Pin	Signal Name
1	VBUS
2	D -
3	D+
4	GND

Connector Terminal Pin Assignment

Serial

For the OS-214 plus, the RS232 connector on the printer side is a female, DB-9.

Pin	Direction	Definition
1	In	DSR
2	In	RxDData
3	Out	TxDData
5	-	Ground
6	Out	DTR
7	Out	RTS
8	In	CTS
9	Out	+5V

Note: Pin 9 on the OS-214 plus is reserved for a KDU (keyboard device unit). Do not connect these pins if you are using a general host such as a PC.

Connection with host:

Host 25S (PC or compatible)	Printer 9P	Host 9S (PC or compatible)	Printer 9P
DTR 20 1 DSR	DTR 4 1 DSR
DSR 6 6 DTR	DSR 6 6 DTR
TX 2 2 RX	TX 3 2 RX
RX 3 3 TX	RX 2 3 TX
CTS 5 7 RTS	CTS 8 7 RTS
RTS 4 8 CTR	RTS 7 8 CTS
GND 7 5 GND	GND 5 5 GND

Alternatively you can connect the 3 wires as follows:

Host 25S (PC or compatible)	Printer 9P	Host 9S (PC or compatible)	Printer 9P
TX 2 2 RX	TX 3 2 RX
RX 3 3 TX	RX 2 3 TX
GND 7 5 GND	GND 5 5 GND
pin 4	□	pin 4	□
pin 5	□	pin 6	□
pin 6	□	pin 7	□
pin 20	□	pin 8	□

The simplest way to connect to other hosts (not PC compatible) or terminals is:

Printer		Terminal/Host
Pin 2- RxData	TxDATA
Pin 3- TxData	RxDATA
Pin 5- Ground	Ground

In general, as long as the data quantity is not too large and you use Xon/Xoff as flow control, it will be problem free.

Baud rate: 1200, 2400, 4800, 9600, 19200, 38400, 57600, 115200 bauds. (Programmable by command)

Data format: 7 or 8 bits

Parity: Odd, Even, or None

Default Parameters : 9600 bauds, no parity, 8 data bits, 1 stop bit

Handshaking: XON/XOFF as well as CTS/RTS (hardware flow control).

If you run an application with the bundled printer driver under Windows and use the serial port, you should check the above parameters and set the flow control to "Xon/Xoff "or "hardware".

Parallel (Centronics)

The parallel port is a standard 36-pin Centronics, which complies with IEEE 1284 standard (compatibility mode). Pin assignments are as follows:

Pin	Direction	Definition	Pin	Direction	Definition
1	In	n/STROBE	16	-	Ground
2~9	In	Data 1~8	17	-	Chassis Ground
10	Out	nACK	18	-	Peripheral High
11	Out	BUSY	19~30	-	Signal Ground
12	Out	PE	31	In	nINIT
13	Out	SELECT	32	Out	nFAULT
14	In	nAUTOFEED	33~35	-	N.D.
15	-	N.D.	36	In	nSELECTIN

Auto Polling

Both the serial port and parallel port of this printer can be activated at the same time, i.e the printer can simultaneously communicate with two PCs via different ports. However as no port contention is made for this printer, if both PCs transmit data at the same time the data may become damaged in the receiving buffer.

ASCII TABLE

NUL			0	@	P	'	P
SOH	XON	!	1	A	Q	a	q
STX		"	2	B	R	b	r
	XOFF	#	3	C	S	c	s
		\$	4	D	T	d	t
	NAK	%	5	E	U	e	u
ACK		&	6	F	V	f	v
BEL		'	7	G	W	g	w
BS		(8	H	X	h	x
)	9	I	Y	i	y
LF		*	:	J	Z	j	z
	ESC	+	;	K	[k	{
FF		,	<	L	\	l	
CR		-	=	M]	m	}
SO	RS	.	>	N	^	n	~
SI	US	/	?	O	_	o	DEL

Appendix I - Installing Dispenser Kit

1. Turn off the printer power and unplug the printer.
2. Unwrap the dispenser kit and take out screws, the shaft, the plastic roller, the dispenser bar, the direction label, and the peeler sensor cable.

Top Cover

3. Take off the top cover of the printer.
4. The peeler sensor cable has a sensor board at one end and a connector at the other end.
5. Mount the two little holes of the sensor board on the two spines at left upper corner inside the top cover, keeping the cable at the left.
6. Route the peeler sensor cable through the guides along the left side of the top cover.
7. Fix the sensor cable and sensor board with Loctite-444 instant adhesive or equivalent.

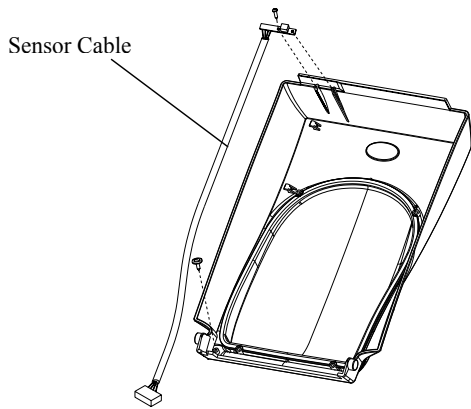

Middle Cover

8. Release the two screws at the bottom of the base housing.
9. Remove the middle cover.
10. Take off the H. Cover.
11. Tape the direction label on the top of the H. cover with the arrow sign heading opposite you.

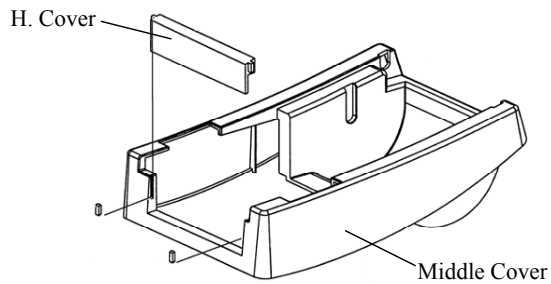

70

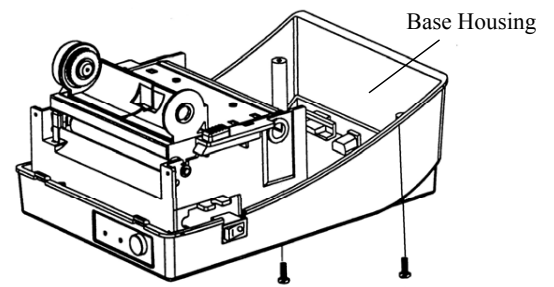

Base Housing

12. Release the screw on the left bracket of the chassis.

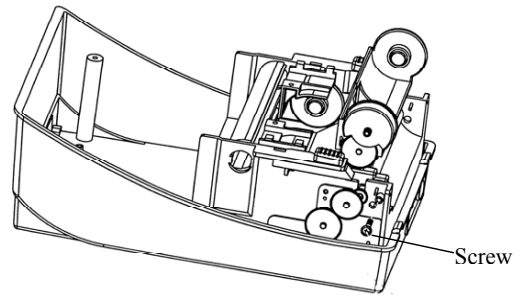

71

13. Unlatch the print head module. Hook the white roller on the brackets of the chassis, ensuring the long thinner end is on the left side.
14. Guide the shaft through the respective holes on the left bracket, the white roller and then the right bracket in order. (To smooth this procedure, hold the white roller with one hand.)
15. Secure the attached screw to the right bracket of the chassis to fix the shaft.
16. Hook the dispenser bar on the brackets of the chassis, positioning it above the white roller. Ensure that the dispenser bar is parallel with the black platen roller and its long thinner end is on the left.
17. Secure the screw on the left bracket of the chassis.
18. Guide the sensor cable connector through the hole on the upper left corner of the middle cover.

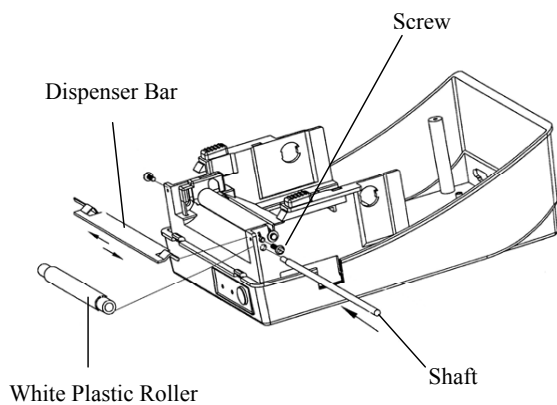

72

19. Click the top cover back onto the middle cover.
20. Insert the sensor connector into its receptacle on the main logic board of the base housing.
21. Click the middle cover back into the base housing. First click in the front then the rear.
22. Secure the two screws at the bottom of the base housing.

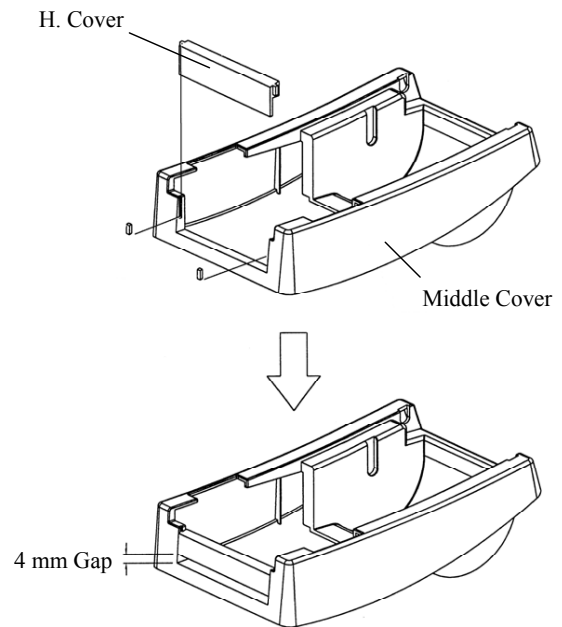

73

Appendix II - Installing the Cutter

1. Turn off the printer power and unplug the power cable and Centronics / Serial cable.
2. Remove the top cover.
3. Remove the two screws under the base housing.

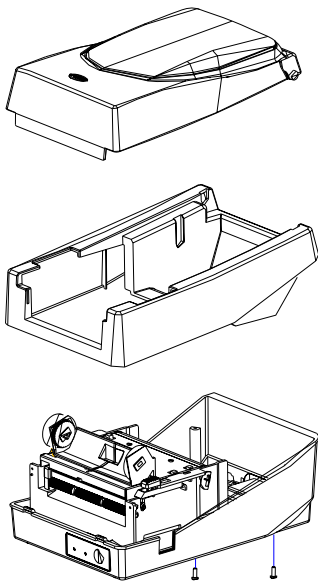

74

4. Remove the whole print head assembly by releasing the 4 screws at its feet.

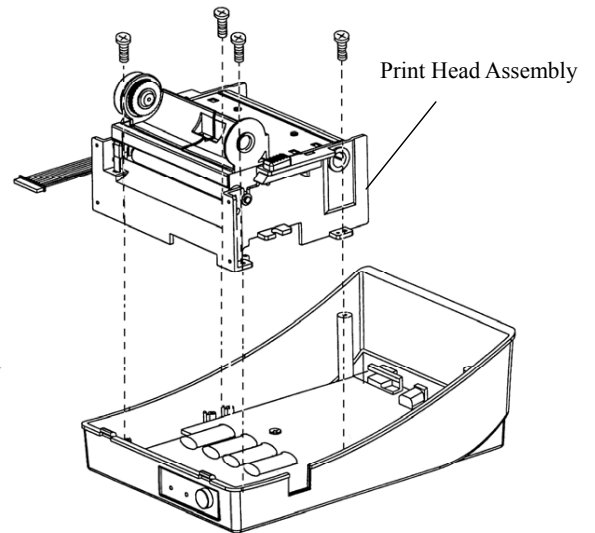

5. Add the cutter IC baby board to J16 on the main board.

75

- Secure the four screws attaching the cutter.

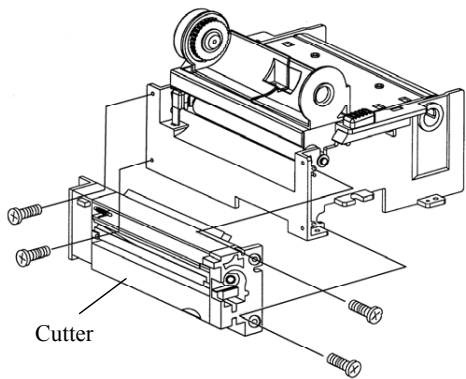

- Plug the cutter's connector into the PCB's header connector (JP16).
- Reattach the print head assembly by securing the 4 screws.
- Click back the middle cover.
- Secure the two screws for the base housing.
- Click the top cover into place.